

CNC Cylindrical Grinder

GP & GA Series

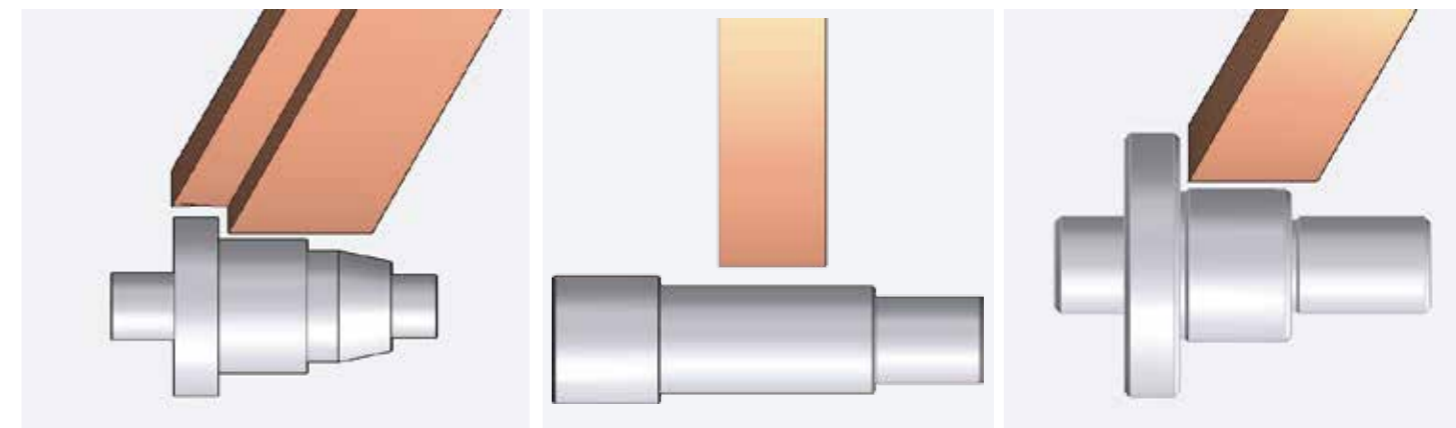

Grinder Professionals

1 GP & GA Series High Precision CNC Cylindrical Grinder

Supertec CNC grinders are designed for high precision, high efficiency, and ease of operation. They are suitable for various applications including but not limited to automotive, aerospace, medical instrument, tooling, job shop, and mold making.

Features

- Supertec Machinery Inc. introduces CNC cylindrical grinders with superb grinding capabilities and choice of control options. The customers' requirements can be met with a choice of many machine options such as a touch probe, automatic sizing device, or swing down ID grinding attachment (plunge type only). The complete product line offers a wide range of between center distances and center heights in both plunge and angular wheelhead designs. Automatic and turnkey solutions can be offered as optional equipment.

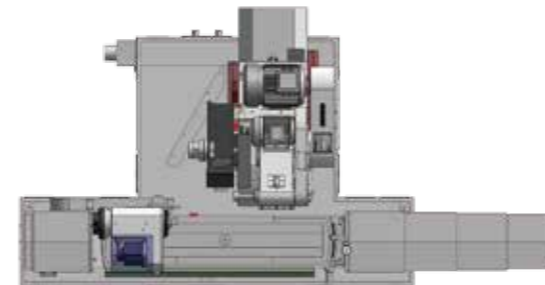

Plunge Wheelhead (GP Series)
Max. Grinding OD: 9"~19"
Distance Between Centers: 20"~118"

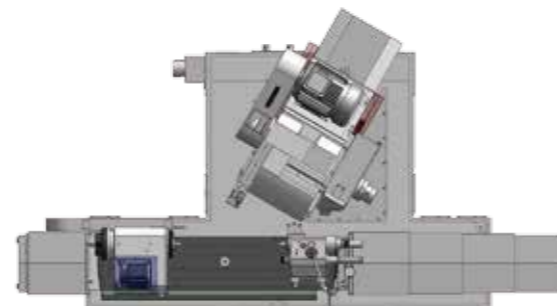

Angular Wheelhead (GA Series)
Max. Grinding OD: 9"~19"
Distance Between Centers: 20"~79"

CNC Controller

- A selection of CNC control systems including Fanuc, Mitsubishi, Siemens, and Conversational PC-BASE are available.
- For small and medium size workpiece grinding operations, Supertec incorporates the optional iGrind graphic conversational programming software.

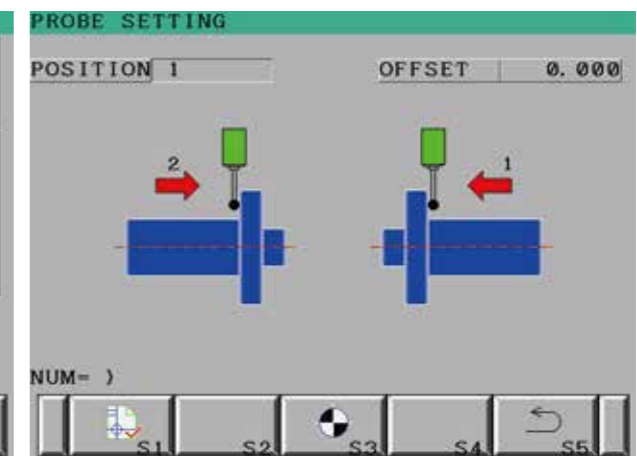
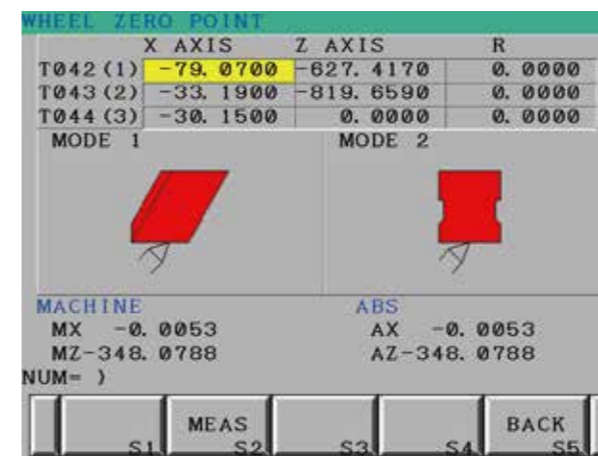
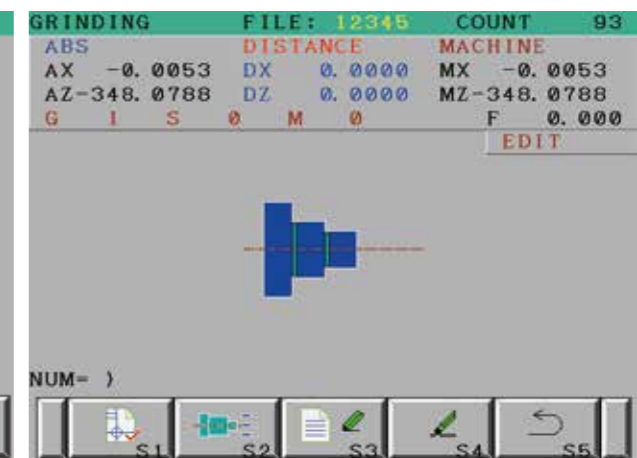
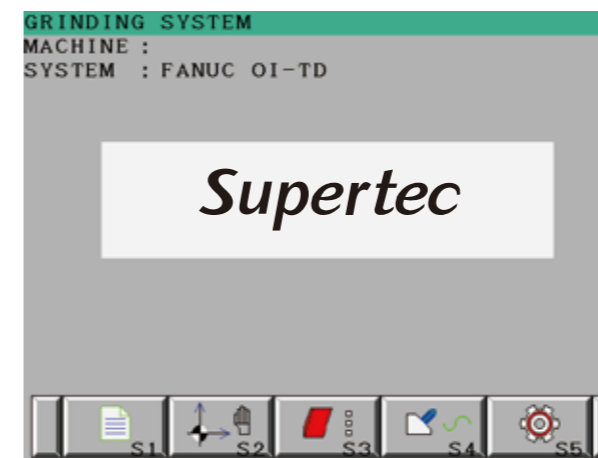

Graphic Conversational Program Functions :

- OD Grinding / End Face Grinding / Form Grinding
- Form Dressing w/ Auto Compensation
- Multiple Section Grinding Sequences
- Setup Parameter Storage
- Graphic Parameter Instruction

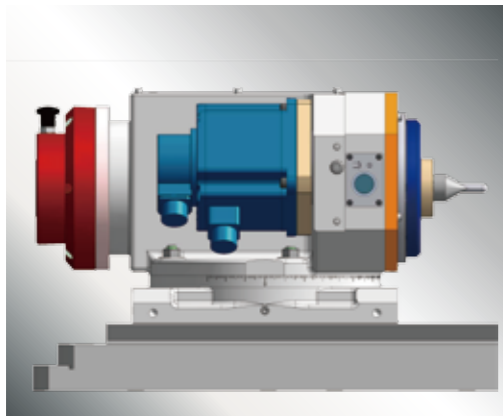

Work Head

NN bearing designed work spindle offers heavy duty load capacity, optimal rotation accuracy, and high rigidity. The servo motor drive offers steady speed and torque during the grinding operation. A positive air purge system keeps grinding swarf and coolant out of the work head, thus it prolongs its life.

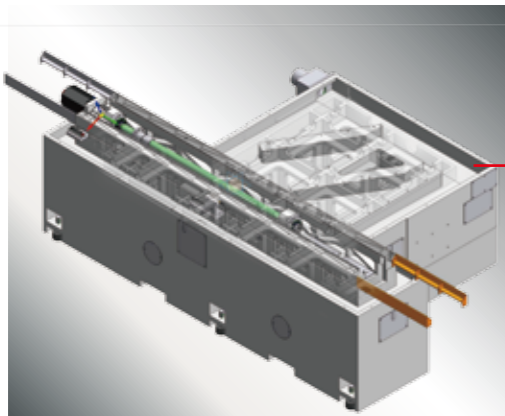

Rigid Machine Base

The machine base is designed to ensure the table is fully supported on both ends. The heavily ribbed box-type base is made of Meehanite casting, providing excellent rigidity and stability of the machine.

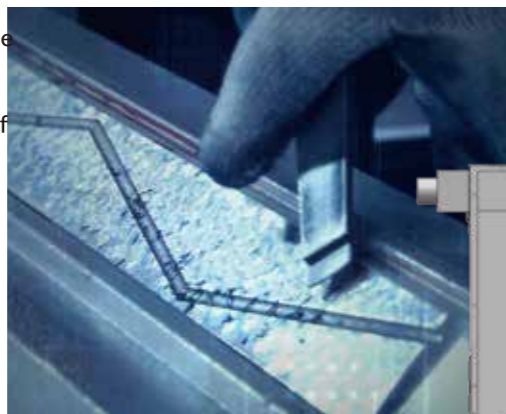

- Supertec
- Other

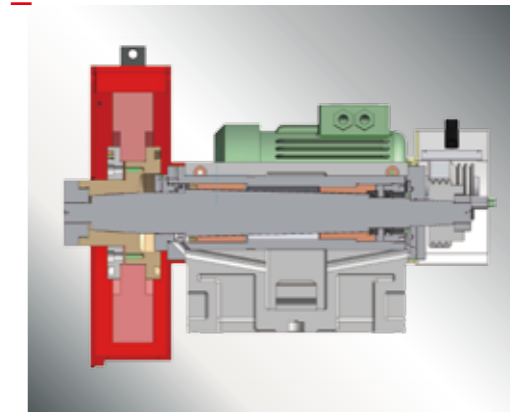
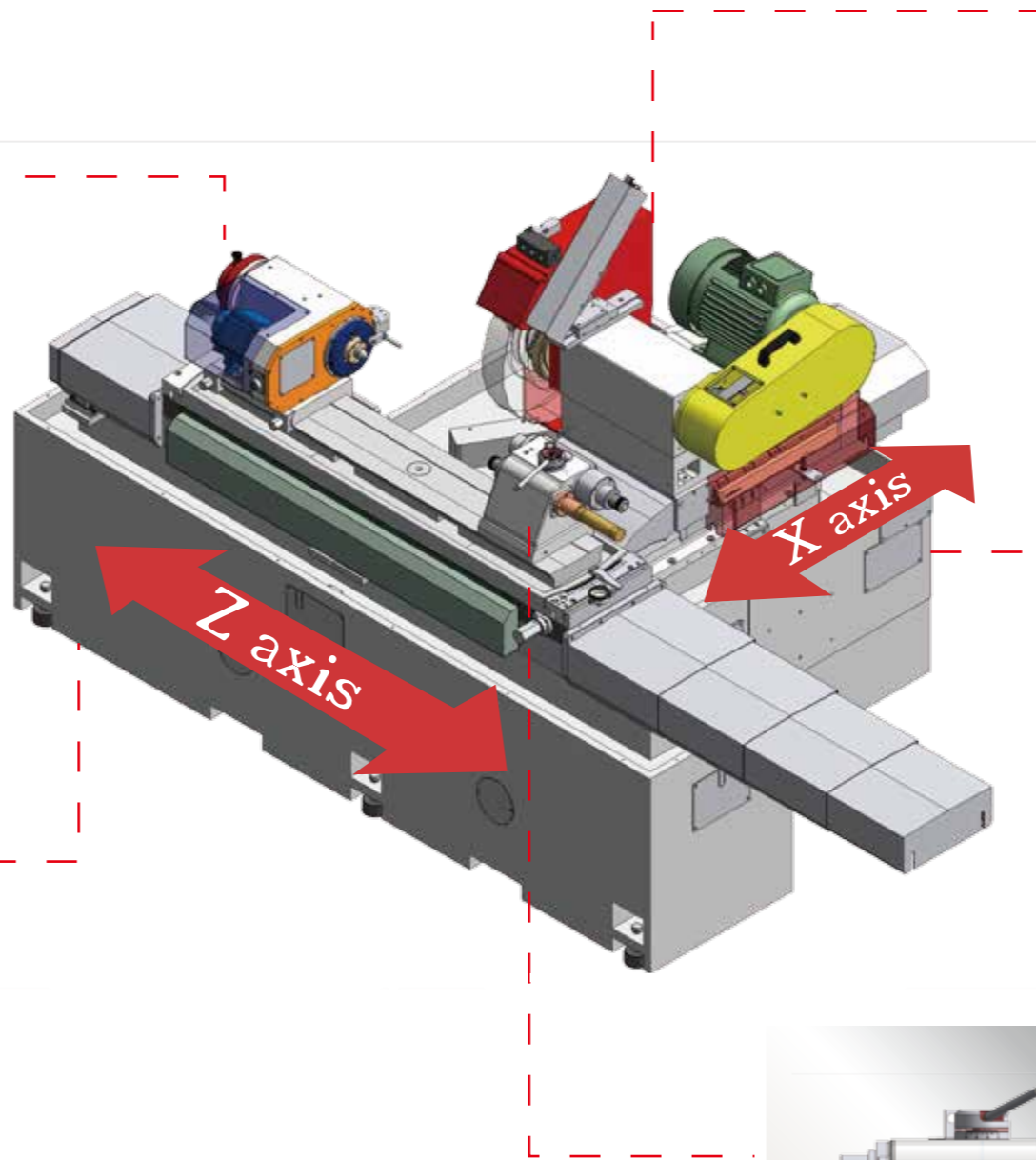
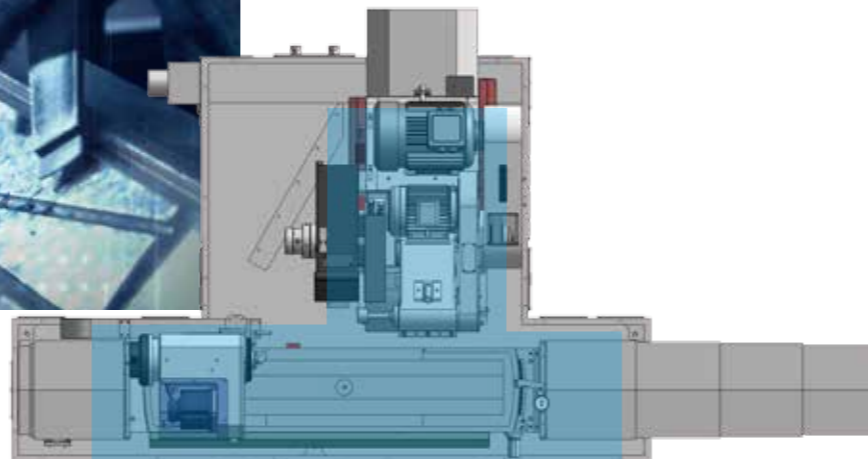

Wheel head Spindle Bearing Options:

- Standard — Contact Bearing Type Spindle is easy to maintain, environmentally friendly and minimizes thermal growth issues.
- Optional — Hydrodynamic Babbit Bearing Type Spindle applies SNM220 super alloy steel with multiple heat treatments makes the surface hardness of spindle up to HRC 62. These features ensure maximum cutting capability and best part finish performance in the grinding operation.

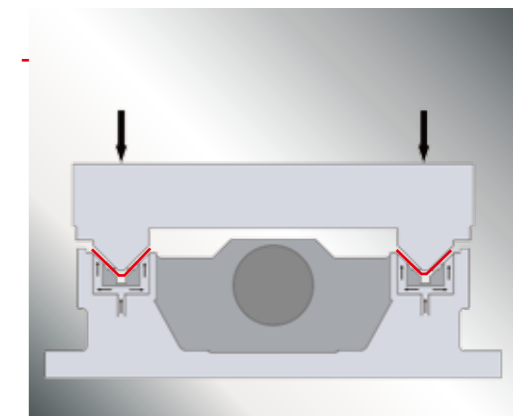

X-axis Guideway

The hand scraped Double V guideways provide maximum support to the wheel head for greater stability and grinding capacity. This design insures superior accuracy over the life of the machine.

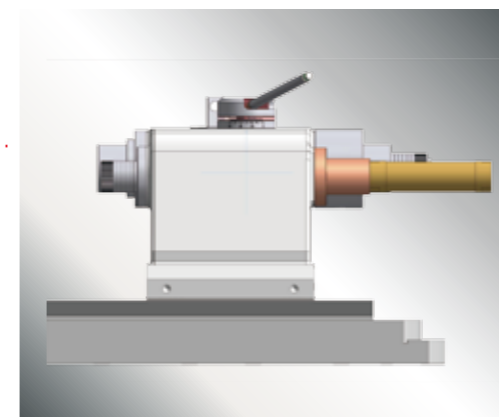

Tailstock

A coolant nozzle is installed on the top of the tailstock for cooling the center tip. An air floating devise allows for smoother movement and protection of the table.

- An optional tailstock quill travel of 3" helps to load/unload the workpiece with ease. The quill is oil-bathed to ensure smooth movement.
- An optional tailstock taper adjustment feature allows the operator to easily adjust for taper error.

Plunge Grinding Example :

Model G32P-60CNC

Grinding Conditions :

Wheel : WA60K(Φ 16")

Workpiece

Name: Standard Grinding Test Workpiece

Material: SCM435

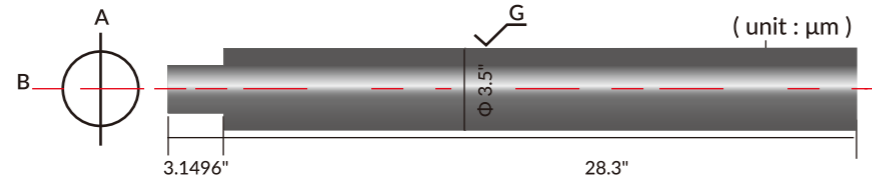

(unit : μm)	1	2	3	4	5	6	7	8	9
A	0.0	0.0	0.0	+1.0	+1.0	+1.0	0.0	0.0	0.0
B	0.0	0.0	0.0	+1.0	+1.0	+1.0	0.0	0.0	0.0

Cylindricity

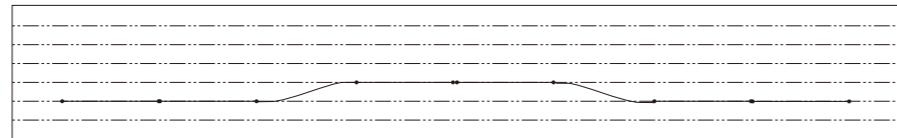

Traverse Grinding Example :

Model G32P-60CNC

Grinding Conditions :

Wheel : WA60K(Φ 16")

Workpiece

Name: Standard Grinding Test Workpiece

Material: SCM435

Roundness :
Part A 0.50 μm

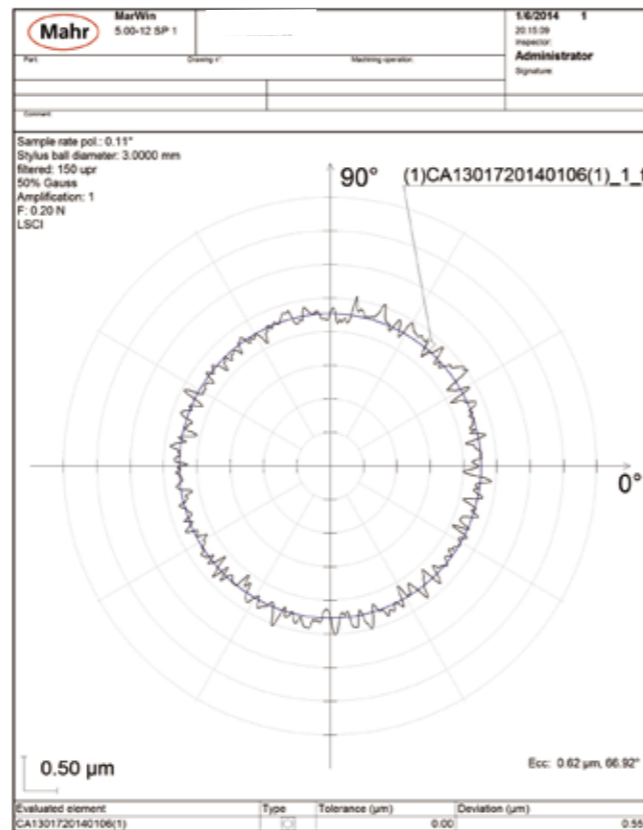
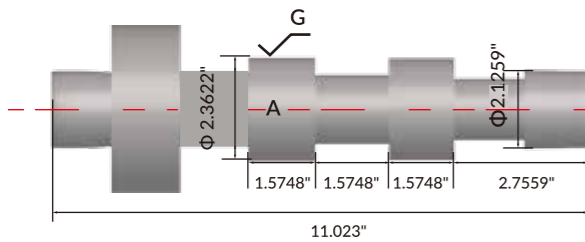

The grinding tests are grinding examples and do not represent actual grinding accuracies.

Wheel Dressing Cycle

Plunge Type

Straight - Parallel

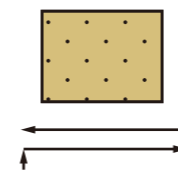

LHS Radius and Concave below

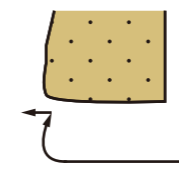

Steps Wheel (option)
(Under 15 points)

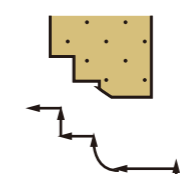

Angular Type

Wheel with radius

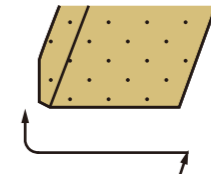

Steps Wheel (option)
(Under 15 points)

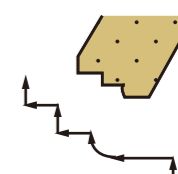

Remarks :

1. Max. 5 types of wheel profile can be saved.
2. Dressing condition can setup rough, intermediate and fine dressing
3. Machine with ID attachment, the dressing operation of ID wheel is manual operated.

Grinding Cycle

Plunge Type

1. Plunge grinding

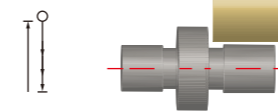

2. Traverse grinding

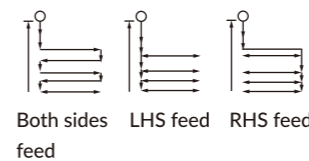

3. Plunge And Traverse grinding

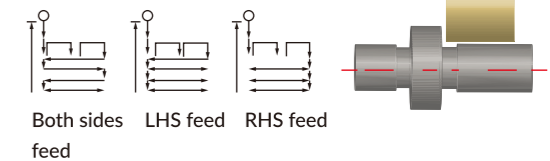

Angular Type

1. Plunge grinding

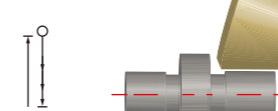

2. Traverse grinding

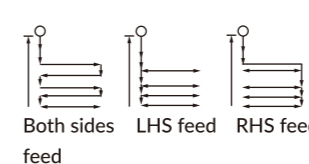

3. Plunge And Traverse grinding

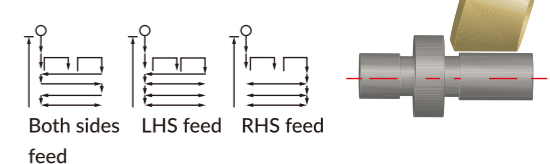

4. OD +End Face Grinding

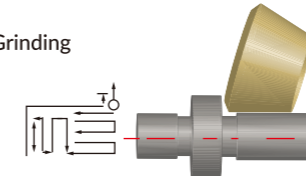

ID Grinding Cycle (using OD Grinding Cycle)

1. Plunge

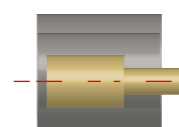

2. Traverse

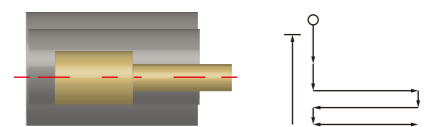

Remarks :

1. All cycles can be separated into rough grinding and fine grinding cycles.
2. Plunge type end face grinding can be implemented by manual operation and offsets.
3. ID grinding coordinate display is not the same to the dimension of the workpiece
4. Multiple steps ID grinding can be implemented by manual operation.



Spindle Shaft
Model: G38P-200CNC

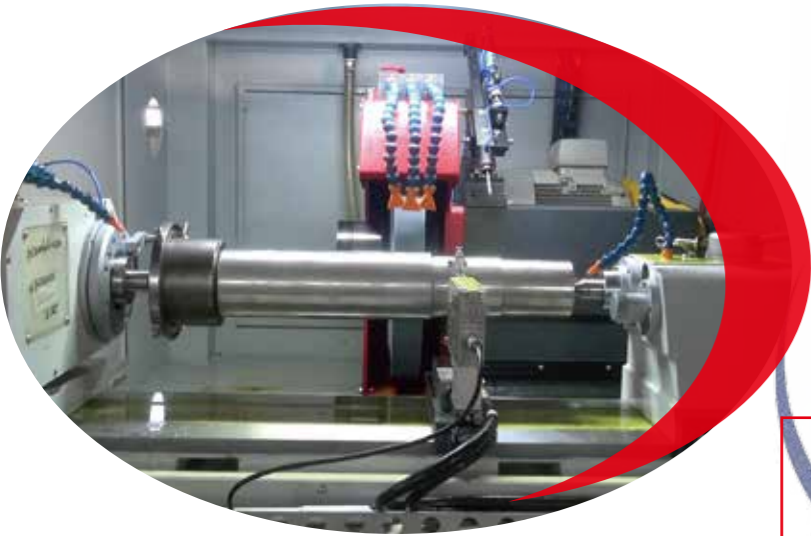

Rotor
Model: G32P-60CNC



Crank Shaft
Model: G32A-60CNC



Printer Roller
Model: G38P-200CNC



Gear Box Helical Gear
Model: G32P-60CNC

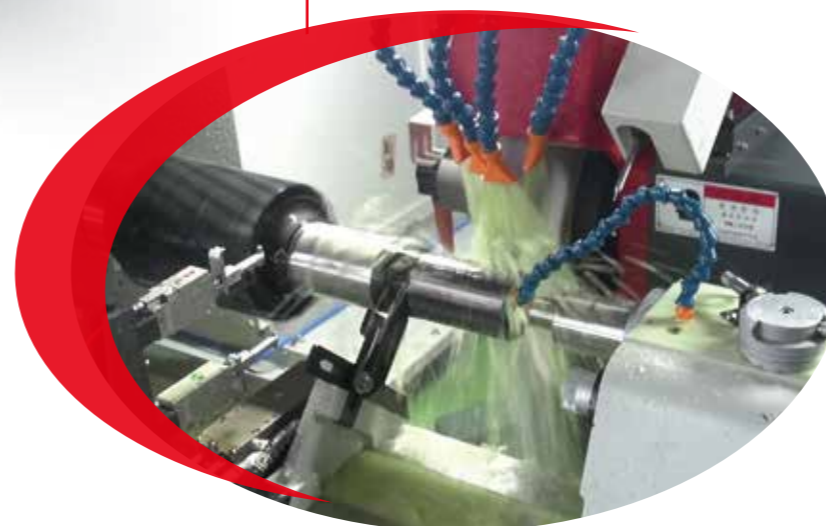

9 Accumulated inspection time of over 100 hours for each machine produced.

We know how it runs and we know how it is inspected

In-Process Inspections

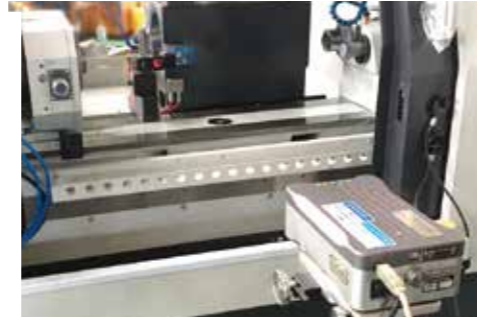

Workpiece Inspections



Mahr cylinder formtester: MMQ400
Mahr Surface Roughness Tester: PERTHOETER M2

Automation Solutions

Due to our extensive engineering knowledge and vast supplier network, we can provide the best grinding solutions.

1. In Process Gauging/Automation
2. Standard Automation Systems
3. Flexible Automation



> General purpose production

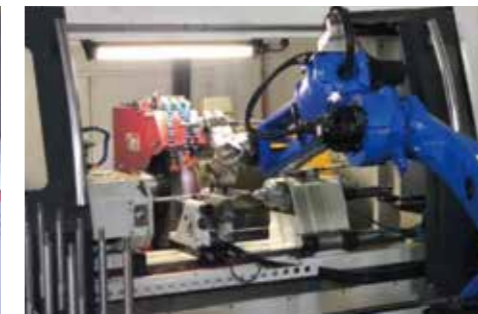

> Load / Unloading solutions
> Gantry Type and 6-axis Robot solution

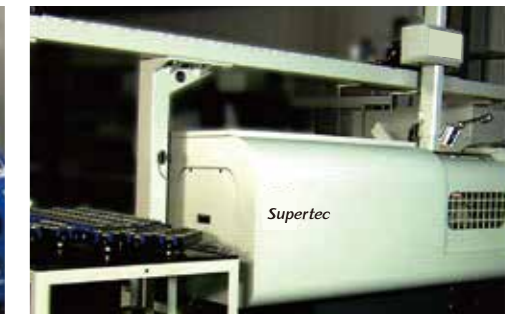

> High Production Units
> Offers total solution for customized production process, grinders with the automation system, and turnkey operations.

MAHR MMQ400 Roundness Measurement

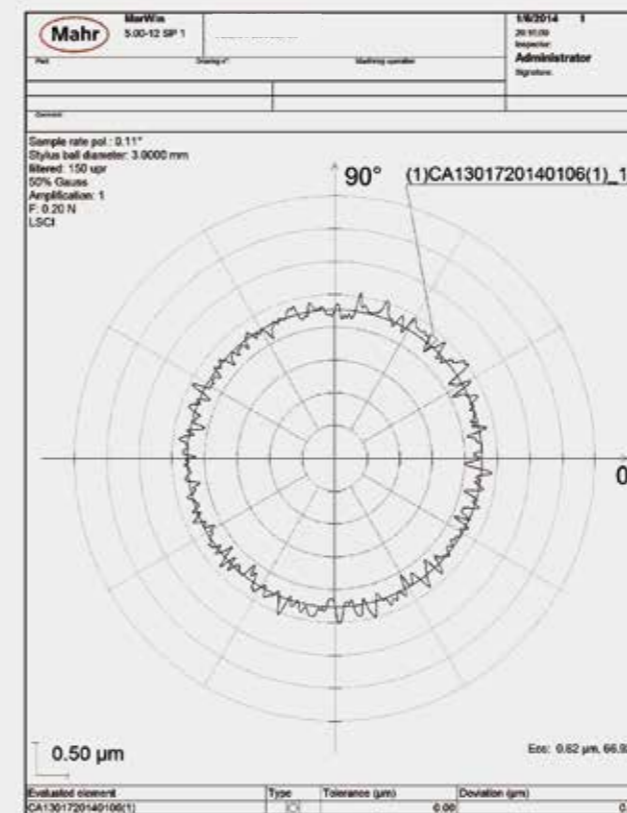

Model		G20P-50CNC	G32P-60CNC	G32P-100CNC	G32P-150CNC	G32P-200CNC	G32P-250CNC	G32P-300CNC	G38P-60CNC	G38P-100CNC	Model	G38P-150CNC	G38P-200CNC	G38P-250CNC	G38P-300CNC	G50P-60CNC	G50P-100CNC	G50P-150CNC	G50P-200CNC	G50P-250CNC	G50P-300CNC	
Grinding	Swing over table	Ø8.0"/Ø10.0"	Ø12.6"	Ø12.6"	Ø12.6"	Ø12.6"	Ø12.6"	Ø12.6"	Ø15.0"	Ø15.0"	Grinding	Swing over table	Ø15.0"	Ø15.0"	Ø15.0"	Ø15.0"	Ø19.6"	Ø19.6"	Ø19.6"	Ø19.6"	Ø19.6"	Ø19.6"
Capacity	Distance between centers	20.0"	24.0"	40.0"	60.0"	80.0"	98.0"	118.0"	24.0"	40.0"	Capacity	Distance between centers	60.0"	80.0"	98.0"	118.0"	24.0"	40.0"	60.0"	80.0"	98.0"	118.0"
	Max. grinding diameter	Ø8.0"/Ø10.0"	Ø11.8"	Ø11.8"	Ø11.8"	Ø11.8"	Ø11.8"	Ø11.8"	Ø14.1"	Ø14.1"	Max. grinding diameter	Ø14.1"	Ø14.1"	Ø14.1"	Ø14.1"	Ø18.9"	Ø18.9"	Ø18.9"	Ø18.9"	Ø18.9"	Ø18.9"	Ø18.9"
	Max. load held between center	Lbs. 176	330	330	330	551	551	551	330	330	Max. load held between center	Lbs. 330	551	551	551	330	330	330	551	551	551	551
	Center distance between spindle & slide table	5.0"	6.3"	6.3"	6.3"	6.3"	6.3"	6.3"	7.5"	7.5"	Center distance between spindle & slide table	7.5"	7.5"	7.5"	7.5"	10.0"	10.0"	10.0"	10.0"	10.0"	10.0"	10.0"
Grinding Wheel	Diameter x Width x Bore	G20P Ø14"x1.5"xØ5"	Ø20"x2"-4"xØ 6"						Ø20"x2"-4"xØ 6"		G25P Opt.Ø18"x2"xØ5" (6" opt.)	Ø24"x2"-4"xØ8"(Opt.)										
	Motor rated power / max. torque	HP/Nm 5HP / 13Nm	10HP/49Nm (Opt.15HP/ 71Nm)						10HP/49Nm (Opt.15HP/ 71)		HP/Nm 5HP / 13Nm	10HP/49Nm (Opt.15HP / 71Nm)										
Workhead	Swiveling angle	deg 90	90						90		deg 90	90										
	Spindle speed (infinite variable)	rpm 10~600	10~600						10~600		rpm 10~600	10~600										
Tailstock	Quill travel	1"	1" (Opt. 2" / 3")						1" (Opt. 2" / 3")		1"	1" (Opt. 2" / 3")										
	Center taper	MT3(Opt.MT4)	MT4 (Opt. MT5)						MT4 (Opt. MT5)		MT3(Opt.MT4)	MT4 (Opt. MT5)										
	Spindle type	Fixed or Rotary	Fixed or Rotary						Fixed or Rotary		Fixed or Rotary	Fixed or Rotary										
	Diameter of bore	Ø0.787"	Ø1.023"						Ø1.023"		Ø0.787"	Ø1.023"										
X Axis	Travel	G20P 6.0"/G25P 7.8"	11.0"						11.0"		11.0"	11.0"										
	Max. rapid feedrate	In/min 236	236						236		In/min 236	236										
	Heidenhain linear scale resolution	0.000002"	0.000002"						0.000002"		0.000002"	0.000002"										
	Servo motor rated power	HP 1.63(F) / 2(M)	2.44 (F) / 3(M)						2.44 (F) / 3(M)		HP 1.63(F) / 2(M)	2.44 (F) / 3(M)										
Z Axis	Travel	G20P 24.0"/G25P 29.5"	35.0"	51.0"	76.0"	96.0"	116.0"	136.0"	35.0"	51.0"	Z Axis	Travel	76.0"	96.0"	116.0"	136.0"	35.0"	51.0"	76.0"	96.0"	116.0"	136.0"
	Swiveling angle	deg ±7	±9	±7	±5	±5	±3	±2	±9	±7	Swiveling angle	deg ±5	±5	±3	±2	±9	±7	±5	±5	±3	±2	
	Max. rapid feedrate	In/min 316	394						394		In/min 316	394										
	Servo motor rated power	HP 1.63(F) / 2(M)	2.44(F) / 3(M)	3.4(F) / 4.75(M)		2.44(F) / 3(M)		2.44(F) / 3(M)		HP 1.63(F) / 2(M)	2.44(F) / 3(M)	3.4(F) / 4.75(M)	2.44(F) / 3(M)		3.4(F) / 4.75(M)							
Motor	Hydraulic pump	HP 1/2	1						1		HP 1/2	1										
	Hydrodynamic GW spindle lubrication pump	HP 1/4	1/4						1/4		HP 1/4	1/4										
	Guide way lubrication pump	HP 1/4	1/4						1/4		HP 1/4	1/4										
	Coolant pump	HP 1/4	1/4						1/4		HP 1/4	1/4										
Machine	Net Weight (semi-enclosed splash guard)	Lbs. G20P 4,400/G25P 6,840	12350	13100	13890	14780	15650	16540	12570	13230	Machine	Net Weight (semi-enclosed splash guard)	Lbs. 14100	14990	15880	16760	12790	13450	14330	15210	16100	16980
	Gross Weight	Lbs. G20P 5,500/G25P 8,380	14100	14770	15650	16540	17420	18300	14330	14990	Gross Weight	Lbs. 15880	16760	17640	18520	14550	15210	16100	16980	17860	18740	

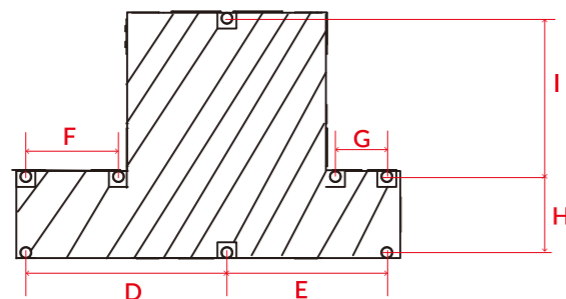
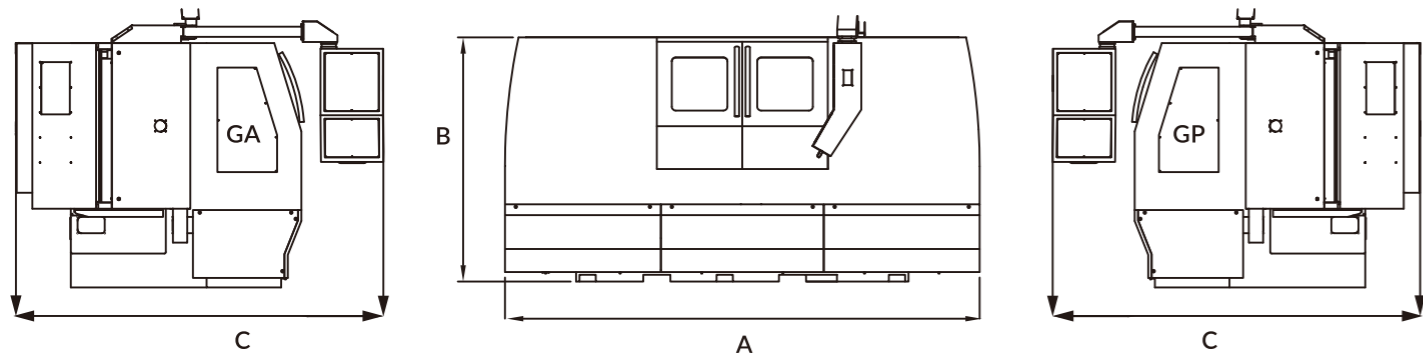

GP	A	B	C	D	E	F	G	H	I
2550	123"	71.2"	90.5"	33.4"	22"	12.1"	10.2"	12.5"	33.8"
3260	137"	70.8"	108.6"	50"	39.7"	23"	15.1"	18.8"	39.3"
32100	169"	70.8"	108.6"	65.7"	55.5"	38.7"	28.5"	18.8"	39.3"
32150	220"	70.8"	108.6"	89.3"	79.1"	52.1"	62.4"	18.8"	39.3"
32200	297"	70.8"	112.2"	113.7"	103.5"	76.5"	86.8"	22"	39.3"
32250	337"	70.8"	112.2"	133.4"	124"	106.2"	96.2"	22"	39.3"
32300	396"	70.8"	112.2"	153.1"	142.9"	126.1"	115.9"	22"	39.3"
3860	137"	70.8"	108.6"	50"	39.7"	23"	15.1"	18.8"	39.3"
38100	169"	70.8"	108.6"	65.7"	55.5"	38.7"	28.5"	18.8"	39.3"
38150	220"	70.8"	108.6"	89.3"	79.1"	52.1"	62.4"	18.8"	39.3"
38200	297"	70.8"	112.2"	113.7"	103.5"	76.5"	86.8"	22"	39.3"
38250	337"	70.8"	112.2"	133.4"	124"	106.2"	96.2"	22"	39.3"
38300	396"	70.8"	112.2"	153.1"	142.9"	126.1"	115.9"	22"	39.3"
5060	137"	70.8"	108.6"	50"	39.7"	23"	15.1"	18.8"	39.3"
50100	169"	70.8"	108.6"	65.7"	55.5"	38.7"	28.5"	18.8"	39.3"
50150	220"	70.8"	108.6"	89.3"	79.1"	52.1"	62.4"	18.8"	39.3"
50200	297"	70.8"	112.2"	113.7"	103.5"	76.5"	86.8"	22"	39.3"
50250	337"	70.8"	112.2"	133.4"	124"	106.2"	96.2"	22"	39.3"
50300	396"	70.8"	112.2"	153.1"	142.9"	126.1"	115.9"	22"	39.3"

GA	A	B	C	D	E	F	G	H	I
2550	123"	71.2"	90.5"	33.4"	22"	12.1"	10.2"	12.5"	33.8"
3260	137"	70.8"	108.6"	50"	39.7"	23"	15.1"	18.8"	39.3"
32100	169"	70.8"	108.6"	65.7"	55.5"	38.7"	28.5"	18.8"	39.3"
32150	220"	70.8"	108.6"	89.3"	79.1"	52.1"	62.4"	18.8"	39.3"
32200	297"	70.8"	112.2"	113.7"	103.5"	76.5"	86.8"	22"	39.3"
3860	137"	70.8"	108.6"	50"	39.7"	23"	15.1"	18.8"	39.3"
38100	169"	70.8"	108.6"	65.7"	55.5"	38.7"	28.5"	18.8"	39.3"
38150	220"	70.8"	108.6"	89.3"	79.1"	52.1"	62.4"	18.8"	39.3"
38200	297"	70.8"	112.2"	113.7"	103.5"	76.5"	86.8"	22"	39.3"
5060	137"	70.8"	108.6"	50"	39.7"	23"	15.1"	18.8"	39.3"
50100	169"	70.8"	108.6"	65.7"	55.5"	38.7"	28.5"	18.8"	39.3"
50150	220"	70.8"	108.6"	89.3"	79.1"	52.1"	62.4"	18.8"	39.3"
50200	297"	70.8"	112.2"	113.7"	103.5"	76.5"	86.8"	22"	39.3"

Model		G25A-50CNC	G32A-60CNC	G32A-100CNC	G32A-150CNC	G32A-200CNC	G38A-60CNC	G38A-100CNC	Model	G38A-150CNC	G38A-200CNC	G50A-60CNC	G50A-100CNC	G50A-150CNC	G50A-200CNC				
Grinding	Swing over table	Ø10.10"	Ø12.6"	Ø12.6"	Ø12.6"	Ø12.6"	Ø15"	Ø15"	Grinding	Swing over table	Ø15"	Ø15"	Ø20"	Ø20"	Ø20"	Ø20"			
Capacity	Distance between centers	20"	24"	40"	60"	80"	24"	40"	Capacity	Distance between centers	60"	80"	24"	40"	60"	80"			
	Max. grinding diameter	Ø9"	Ø11.8"	Ø11.8"	Ø11.8"	Ø11.8"	Ø14"	Ø14"		Max. grinding diameter	Ø14"	Ø14"	Ø19"	Ø19"	Ø19"	Ø19"			
	Max. grinding length - dresser on workhead side	13.7"	17.7"	33"	53"	73"	17.7"	33"			Max. grinding length - dresser on workhead side	53"	72"	17"	33"	53"	72"		
	- dresser on tailstock side (Opt.)	20"	24"	40"	60"	80"	24"	40"				Max. load held between center	60"	80"	24"	40"	60"	80"	
	Max. load held between center	Lbs. 176	330	330	330	550	330	330					Center distance between spindle and slide table	330	550	330	330	330	550
Center distance between spindle and slide table	5"	6"	6"	6"	6"	7.5"	7.5"	7.5"	7.5"					10"	10"	10"	10"	10"	
Grinding	Infeed angle	deg 60	60	60	60	60	60	60	Grinding	Infeed angle				deg 60	60	60	60	60	60
Wheel	Diameter x Width x Bore	Ø18"x2"xØ 5"	Ø20"x2"-4"xØ6"			Opt. Ø24"x2"-4"xØ8"			Wheel	Diameter x Width x Bore	Ø20"x2"-4"xØ6"			Opt. Ø24"x2"-4"xØ8"					
	Motor rated power / max. torque	HP/Nm 5HP / 13Nm	10HP/49Nm(Opt.15HP/ 71Nm)			10HP/49Nm(Opt.15HP/ 71Nm)				Motor rated power / max. torque	HP/Nm 10HP/49Nm(Opt.15HP/ 71Nm)	10HP/49Nm(Opt.15HP/ 71Nm)							
	Wheel speed	rpm 1400	1250 (Opt.1650)			1250 (Opt.1650)					Wheel speed	rpm 1250 (Opt.1650)	1250 (Opt.1650)						
	Workhead Swiveling angle	deg 90	90			90						Workhead Swiveling angle	deg 90	90					
	Spindle speed (infinite variable)	rpm 10~600	10~600			10~600							Spindle speed (infinite variable)	rpm 10~600	10~600				
Motor rated power / max. torque	HP 1	2			2			Motor rated power / max. torque	HP 2					2					
Center taper	- MT3	MT4 (Opt. MT5)			MT4 (Opt. MT5)				Center taper	- MT4 (Opt. MT5)				MT4 (Opt. MT5)					
Spindle type	- Fixed or Rotary	Fixed or Rotary			Fixed or Rotary					Spindle type	- Fixed or Rotary			Fixed or Rotary					
Diameter of bore	Ø0.787"	Ø1.023"			Ø1.023"						Diameter of bore	Ø1.023"		Ø1.023"					
Tailstock	Quill travel	1"	1" (Opt. 2" / 3")			1" (Opt. 2" / 3")						Tailstock	Quill travel	1" (Opt. 2" / 3")			1" (Opt. 2" / 3")		
	Center taper	- MT3	MT4 (Opt. MT5)			MT4 (Opt. MT5)							Center taper	- MT4 (Opt. MT5)	MT4 (Opt. MT5)				
	X Axis Travel	7.8"	11"			11"			X Axis Travel					11"	11"				
Max. rapid feedrate	In/min 236	236			236			Max. rapid feedrate		In/min 236		236							
Heidenhain linear scale resolution	0.000002"	0.000002"			0.000002"					Heidenhain linear scale resolution	0.000002"	0.000002"							
Min. increment	0.000010"	0.000010"			0.000010"						Min. increment	0.000010"	0.000010"						
Servo motor rated power	HP 1.6(F)/2(M)	2.5(F)/3(M)			2.5(F)/3(M)							Servo motor rated power	HP 2.5(F)/3(M)	2.5(F)/3(M)					
Z Axis Travel	29.5"	35"	51"	76"	96"	35"	51"		Z Axis Travel				76"	96"	35"	51"	76"	96"	
Swiveling angle	deg ±7	±9	±7	±5	±5	±9	±7	Swiveling angle					deg ±5	±5	±9	±7	±5	±5	
Max. rapid feedrate	In/min 314	394			394					Max. rapid feedrate			In/min 394	394					
Min. increment	0.000010"	0.000010"			0.000010"						Min. increment		0.000010"	0.000010"					
Servo motor rated power	HP 1.6(F)/2(M)	2.5(F)/3(M) 3.3(F)/4.6(M)			2.5(F)/3(M)							Servo motor rated power	HP 3.3(F)/4.6(M)	2.5(F)/3(M) 3.3(F)/4.6(M)					
Motor	Hydraulic pump	HP 1	1			1			Motor				Hydraulic pump	HP 1	1				
	Hydrodynamic GW spindle lubrication pump	HP 1/4	1/4			1/4							Hydrodynamic GW spindle lubrication pump	HP 1/4	1/4				
	Guide way lubrication pump	HP 1/4	1/4			1/4				Guide way lubrication pump				HP 1/4	1/4				
	Coolant pump	HP 1/4	1/4			1/4					Coolant pump			HP 1/4	1/4				
	Machine	Net Weight (semi-enclosed splash guard)	Lbs. 6,900	12,400	12,800	13,900	14,800	12,400				12,800		Machine	Net Weight (semi-enclosed splash guard)	Lbs. 13,900	14,800	12,400	12,800
Gross Weight		Lbs. 7,800	14,200	16,600	17,200	18,100	14,200	16,600	Gross Weight			Lbs. 17,200			18,100	14,200	16,600	17,200	18,100

Standard Accessories

- Infinite variable workhead w/servo motor
- Diamond Dresser and Stand
- Automatic wheel speed change (15 steps)
- Carbide tip center
- X Axis Heidenhain linear scale (resolution 0.05 um)
- Levelling bolts and blocks
- Operation manual and part lists
- Fanuc CNC Controller (Oi TF)
- Grinding Wheel + Wheel Flange
- Standard oil cooler (cooling fan)

- Standard coolant tank 140L
- MPG handwheel 2 Axes control
- Touch probe (for EGA series only)
- LED working light
- Tools and Tool Box
- Electricity cabinet w/ heat exchanger
- Semi-enclosed splash guard
- Wheel Extractor
- 4-color indication signal light
- Electrical wiring diagram

* Supertec reserves the right to change specifications without notice

Optional Accessories

- BS VM25 Integration system (OD gauging+ crash & gap control + dynamic balance system)
- BS VM15 Integration system (OD gauging+ crash & gap control)
- Hydraulic tailstock (w/ foot pedal)
- Z Axis Heidenhain linear scale (resolution 0.05 um)
- Manual grinding wheel balance system (vibrator)
- Grinding wheel dynamic balance system
- Wheel spindle lubrication oil cooler for hydrodynamic spindle
- Gap & crash control device
- Safety door lock
- Workhead spindle adjustment arbor
- Auto gauging device
- Coolant system with magnetic separator & paper filter
- Coolant system with magnetic separator
- Coolant system with paper filter
- Oil & mist collecting system
- Spare grinding wheel flange
- Full-Carbide center tip
- FANUC Oi-TF iGrind program
- Mitsubishi controller (M80) iGrind program
- Electrical cabinet air conditioner
- Internal grinding attachment (for EGP series only)
- Workhead upgrade to MT5 (not suitable for 25 series)
- Tailstock upgrade to MT5 (not suitable for 25 series)
- Roller type balancing stand/ arbor
- Automatic 3-jaw hydraulic chuck
- CE standard electrical cabinet
- Touch probe
- Transformer
- Workpiece carrier
- Full-enclosed splash guard
- Workpiece supporting seat, 2pc / set
- 2 Point Steady Rest
- 3-point steady rest
- 3-jaw scroll chuck
- 4-jaw scroll chuck